

Adding Bluetooth monitoring to your Slimline Lithium Battery

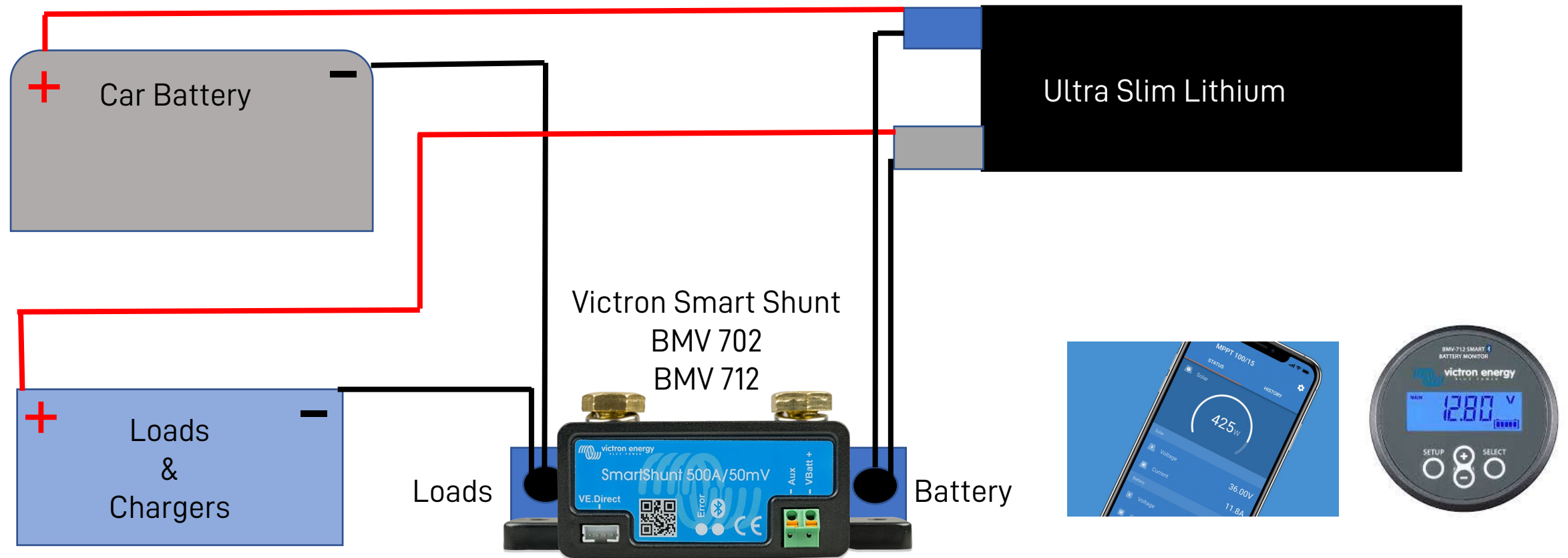

Providing power to start using your Ultra Slimline Lithium Battery

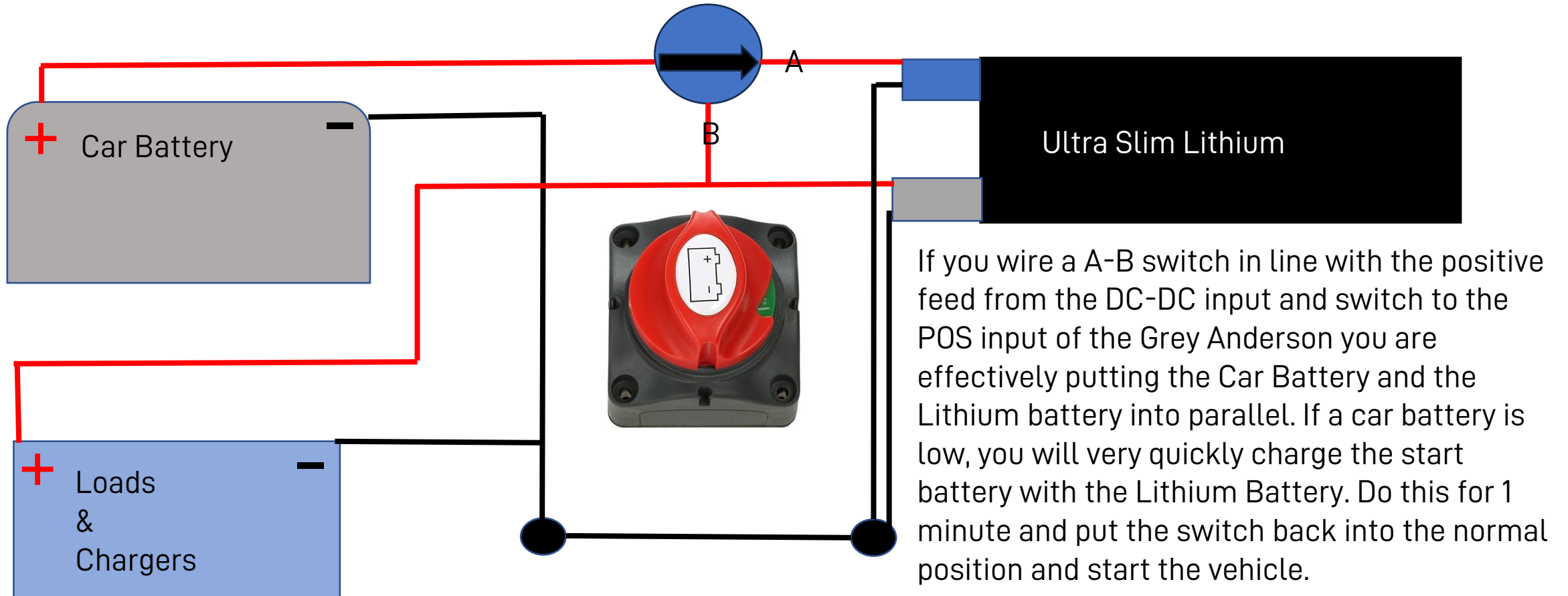

If you wire a A-B switch in line with the positive feed from the DC-DC input and switch to the POS input of the Grey Anderson you are effectively putting the Car Battery and the Lithium battery into parallel. If a car battery is low, you will very quickly charge the start battery with the Lithium Battery. Do this for 1 minute and put the switch back into the normal position and start the vehicle.