



Toyota Land Cruiser Prado 1GD-FTV Direction-Plus™ ProVent® 200 Installation Guide

This document is to be used as a guide for the installation of the Direction-Plus™ Land Cruiser Prado 150 Series ProVent® 200 Crankcase Ventilation Kit to a 2015-ON Toyota Land Cruiser Prado 150 Series Diesel with the 1GD-FTV 2.8L engine. It is recommended that the installation of the product be carried out by a competent qualified mechanic.

Important Before Starting

- Ensure you have the correct tools to complete the fitment
- Read the instructions in full and familiarize yourself with the installation, before commencing any work

Included in the kit

- 1 x Mann + Hummel ProVent® 200
- 1 x Mounting Bracket
- 1 x 550mm of 19mm Hose
- 1 x 650mm of 16mm Hose
- 1 x 19mm 90° Joiners
- 1 x 16mm 90° joiner
- 1 x 25-19mm coupler
- 1 x 25-16mm coupler
- 2 x 25mm Spring Clamps
- 3 x 19mm Spring Clamps
- 3 x 16mm Spring clamps
- 8 x Cable Ties
- 1 x M6x12 Bolt
- 1 x M6 Spring Washer
- 1 x M6 flat washer
- 1 x M8 nyloc nut
- 2 x M8x25 Bolts
- 4 x M8 Flat Washers
- 1 x 1000mm of 12mm Hose
- 1 x Drain Tap Assembly
- 2 x 12-20mm Hose Clamps

*Kit contents are subject to change based on component availability and/or refinement

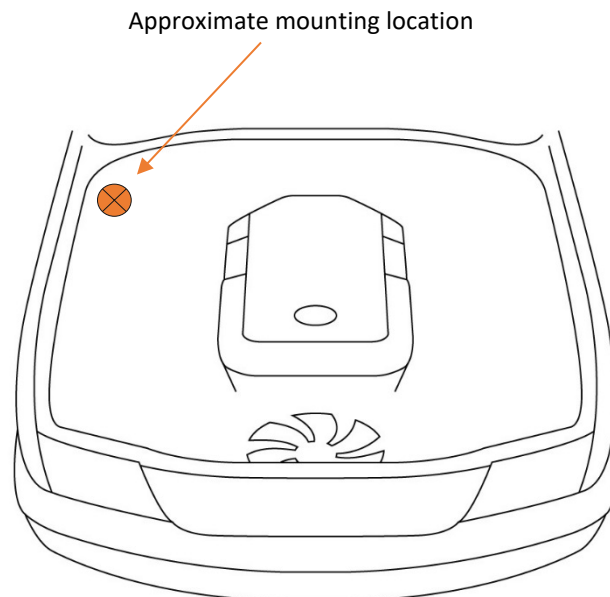

Installation Guide

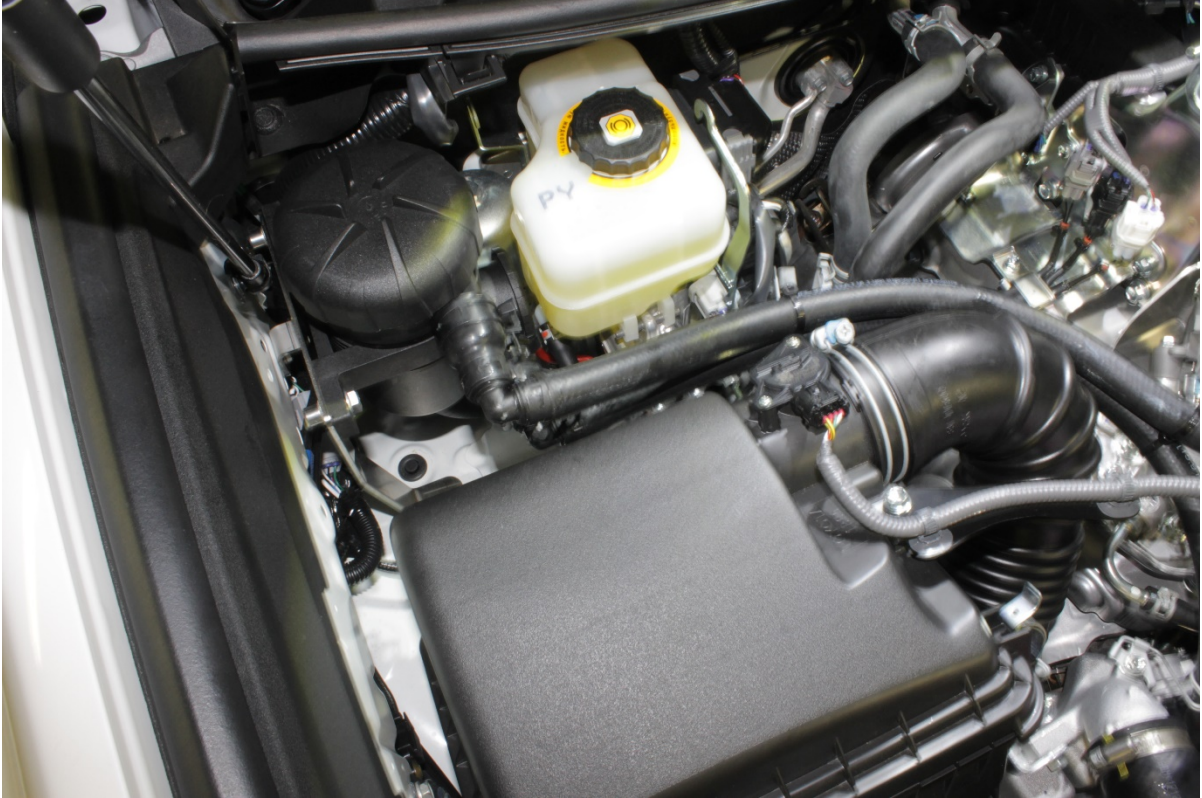

Land Cruiser Prado 150 Series Engine Bay – Overall View

1. Begin by unclipping the harness plug from the side of the engine bay (shown below) and bolting the new ProVent® Bracket to the rear corner of the engine bay. It uses an M8 nut and washer at the base and an M6 bolt and washer on the side to secure it to factory mounting locations.

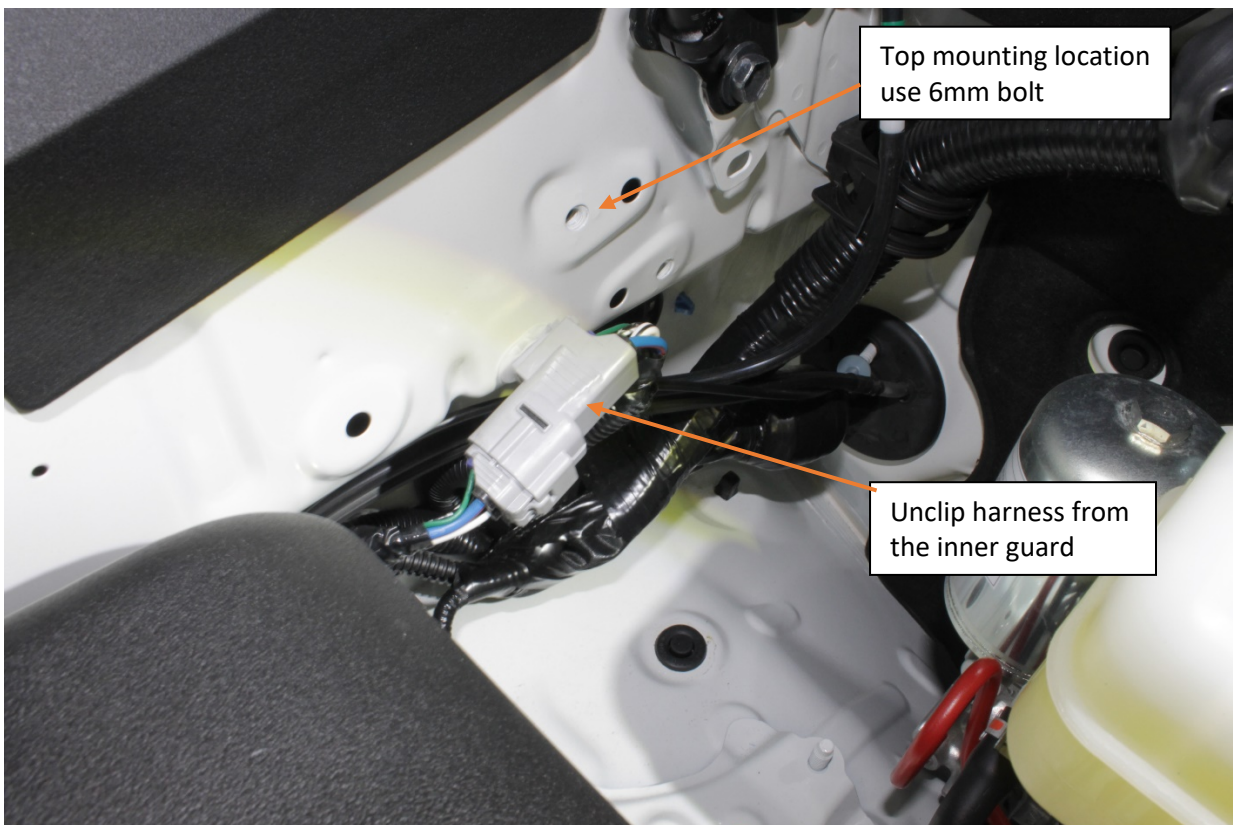

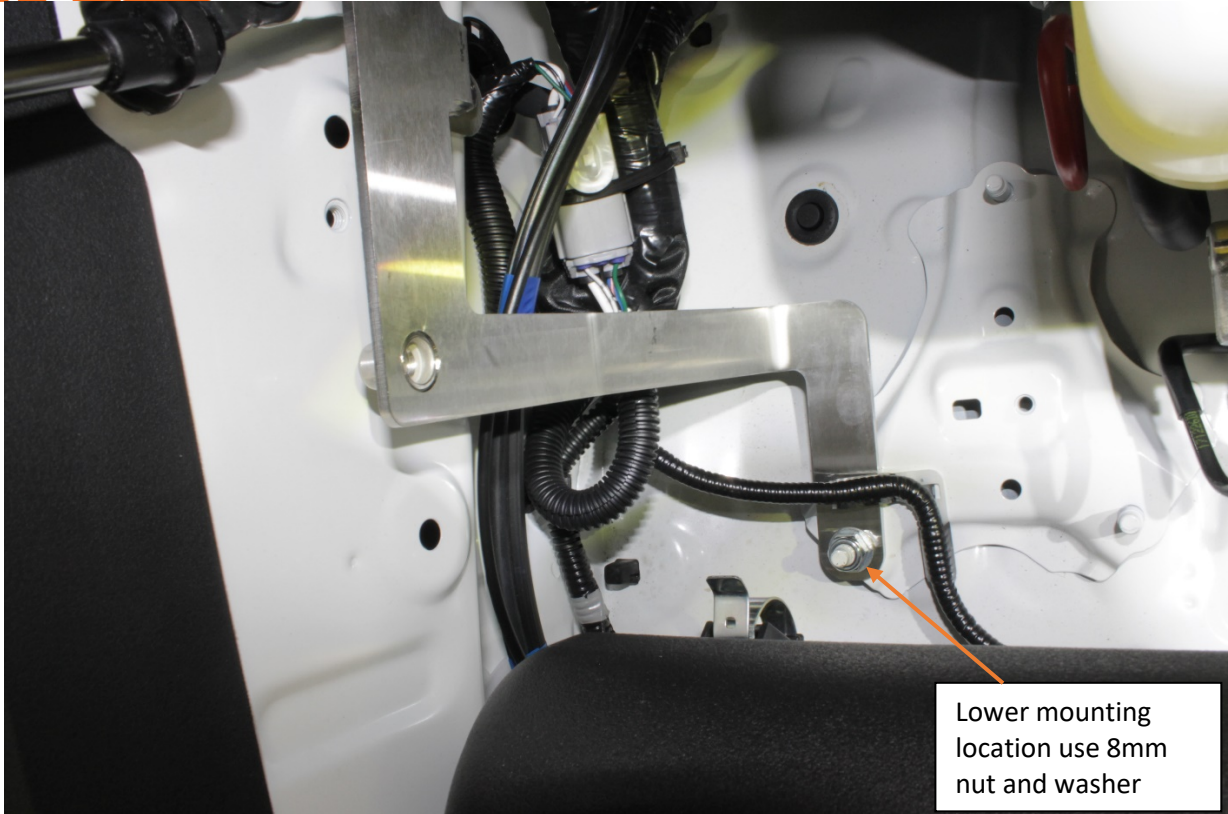

Land Cruiser Prado 150 Series ProVent® Bracket Mounting

2. Connect the 12mm (1/2") Hose to the drain of the ProVent® body, using a 12-20mm Clamp to secure it in place.



Provent® 200 with 12mm hose connected and secured with 12-20mm spring clamp

3. With a flat washer and spring washer on each of the M8x25mm bolts, mount the ProVent® 200 to the mounting bracket.

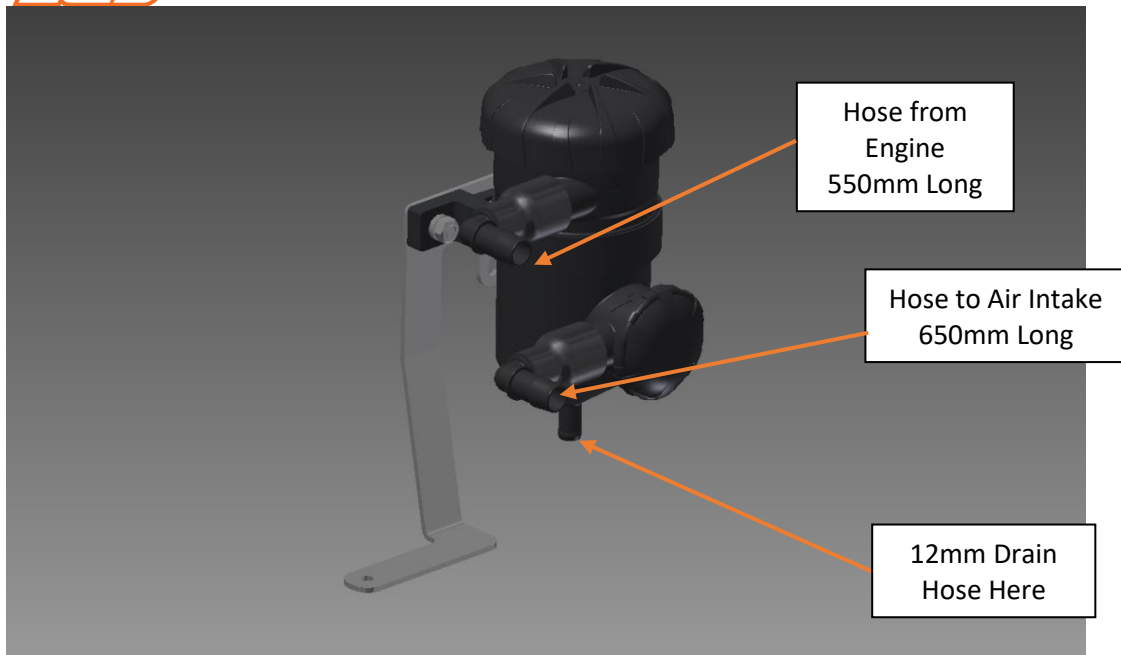

Pre-assembled ProVent® 200 with bracket – Please note ProVent rotation in this image is correct, your ProVent should come at the correct rotation in the box – if it is not, refer to the image on the last page of this installation guide.

4. Feed the 12mm Hose down the side of the engine bay, under the vehicle to an out of the way location, making sure it is clear of any suspension, driveline and exhaust components, fit the Tap hose tail into the hose and secure with a 12-20mm clamp.



Hose tail and tap assembly inserted into 12mm hose, hose clamp not required.

5. Use the supplied cable ties to secure the 12mm hose into the location required under the vehicle to prevent movement. Note: Leave a slight amount of slack in the line where the body and chassis join to prevent stretching the hose.
6. Make sure the tap position is closed and avoid placing the tap in a location in which it will fill with dirt and mud.

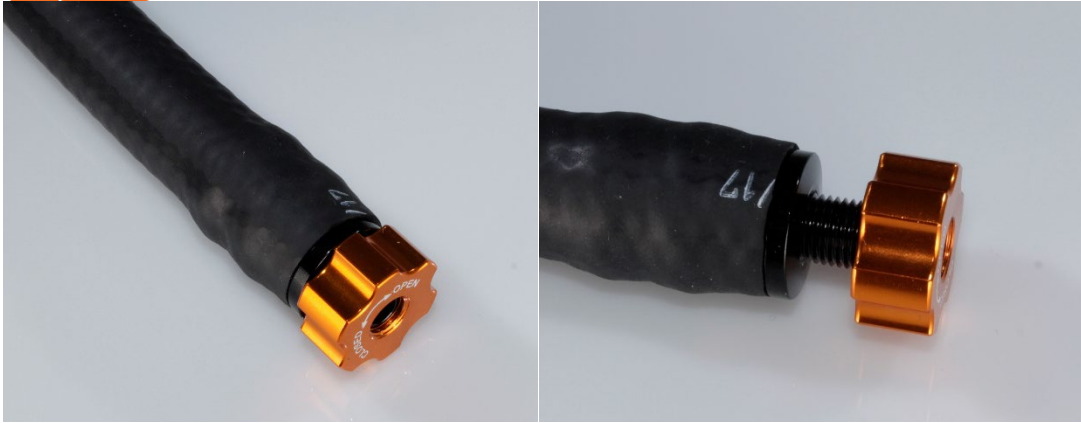

Left image – Tap Open.

Right image – Tap Closed.

7. Disconnect and remove the factory bypass hose from the valve cover on the engine
8. Mount one end of the 550mm long 19mm hose to the now vacant outlet on the valve cover of the engine. You can use a hose clamp here if you wish, there are enough in the kit (The factory hose has no clamps).
9. Run the other end of the 550mm long hose to the top 19mm 90° joiner fitting on the ProVent®. You may need to trim it to suit your needs. Secure in place with a spring clamp.
10. Mount one end of the 650mm 16mm hose to the lower 16mm 90° joiner fitting on the ProVent® 200. Secure in place with a hose clamp.

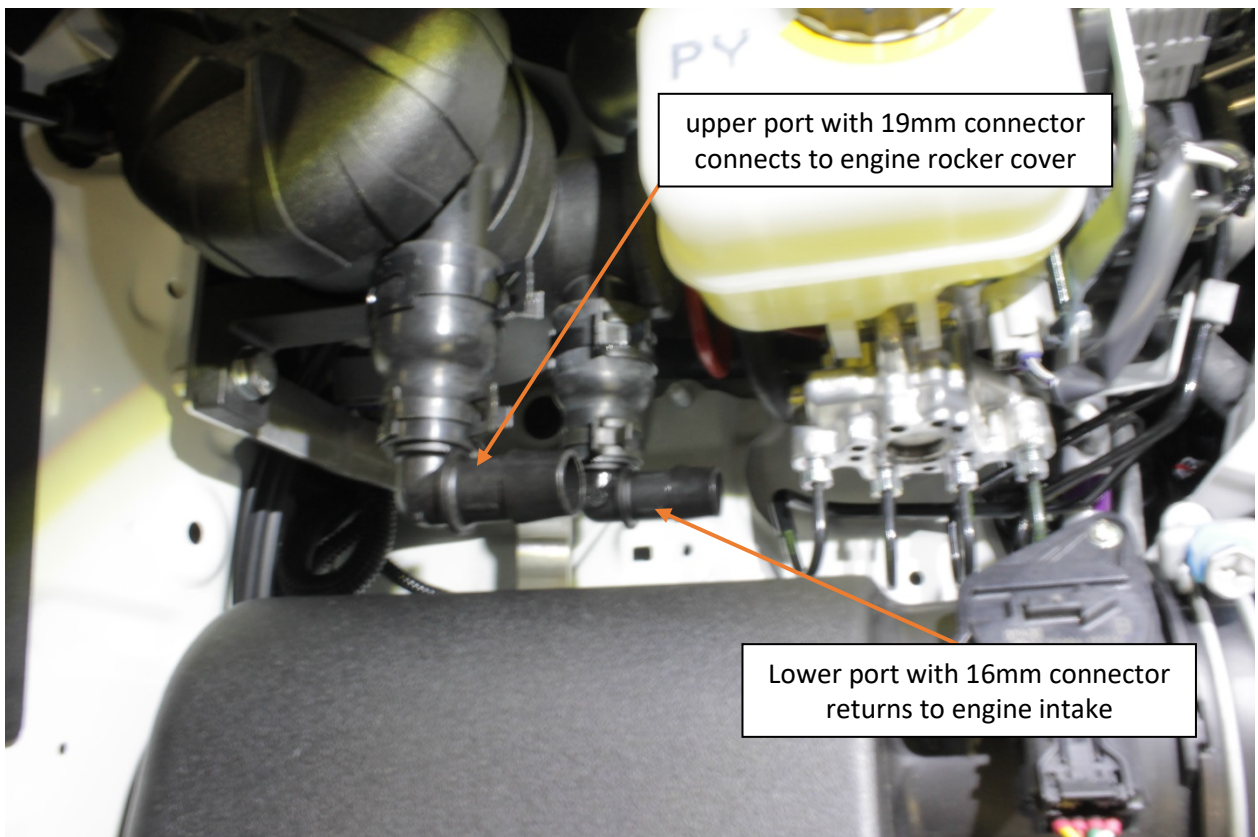

11. Routing the 650mm hose to the engine intake connect the 16mm hose to the intake where the factory bypass hose was removed and secure with a clamp (shown below). You may need to trim this hose to suit depending on how the hose has been routed.

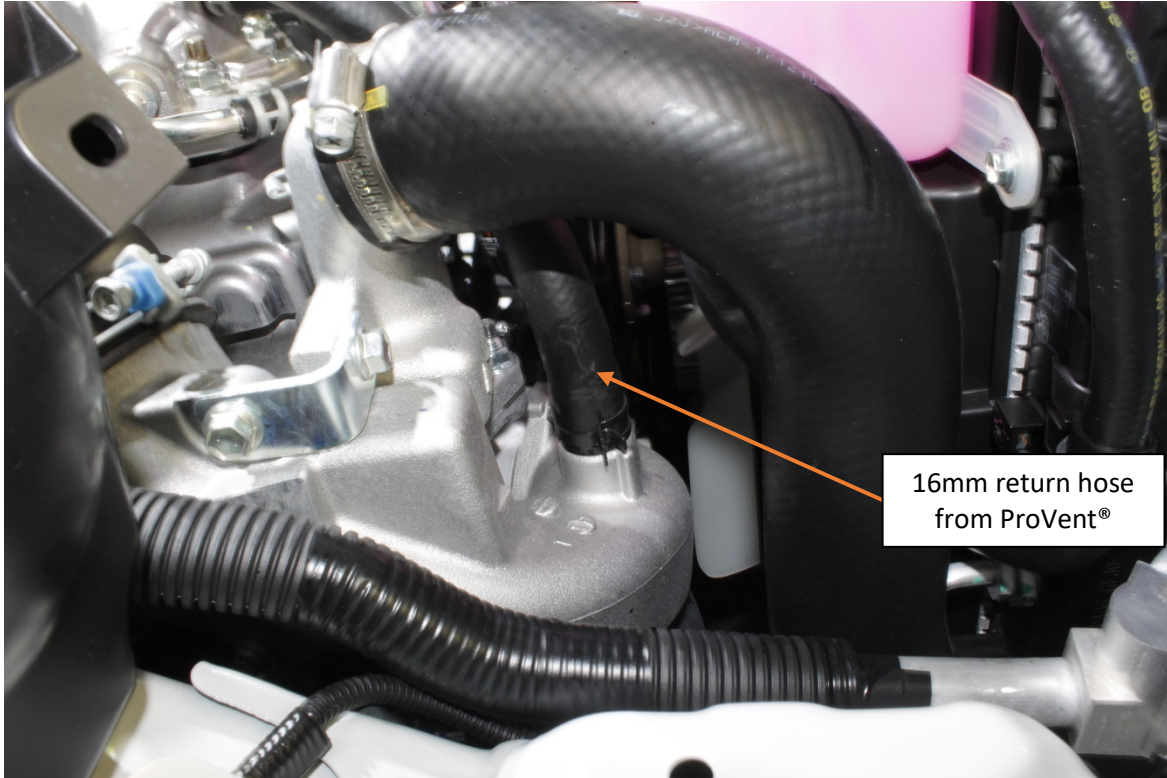

12. Cable ties the hoses together to prevent rubbing on any components.

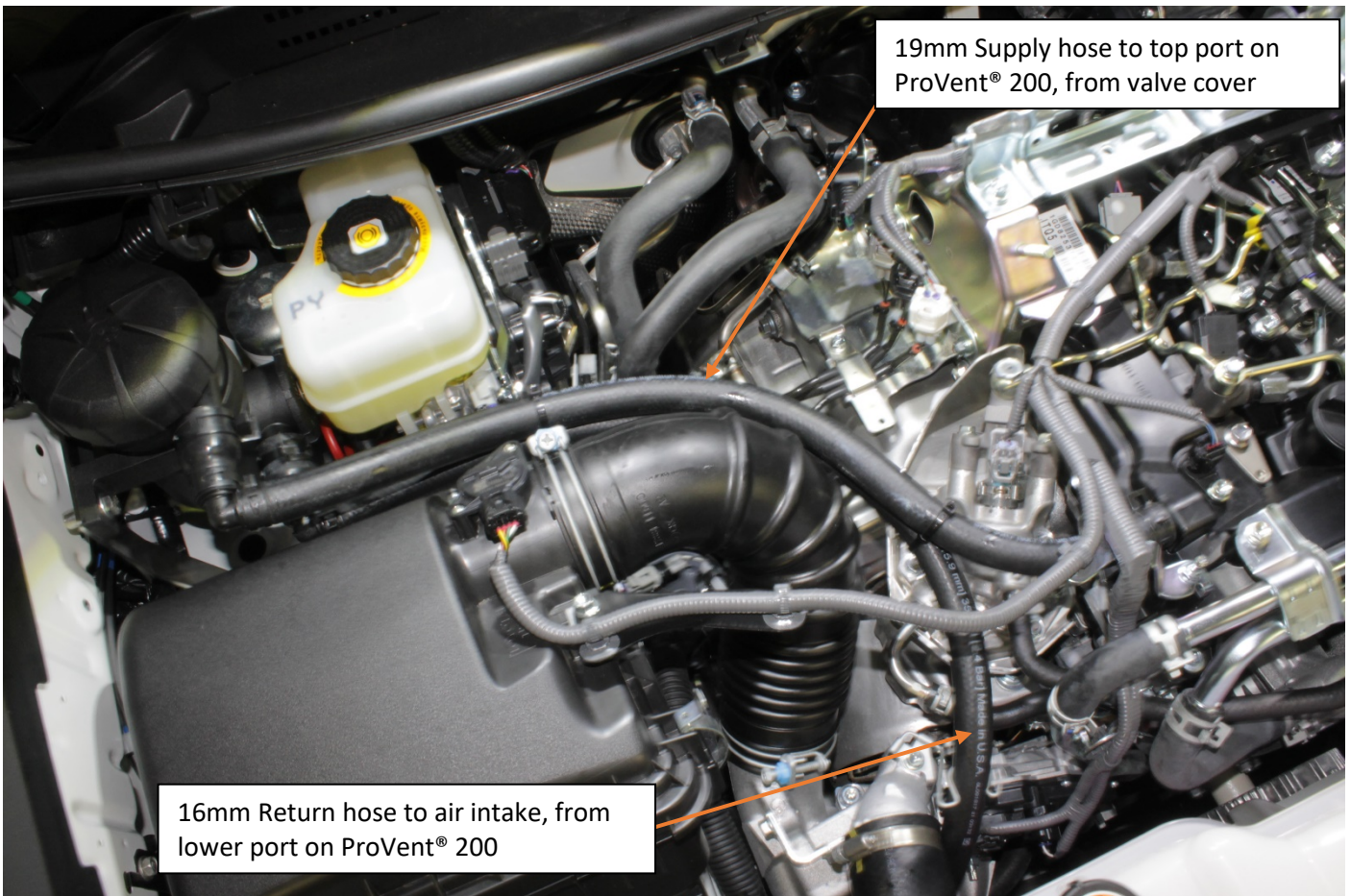

Hose configuration in Land Cruiser Prado 150 Series with ProVent® 200 installed

ProVent 200

The housing can (prior to installation) be turned in the holder in 30° steps around the longitudinal axis.

This enables the position "Inlet and outlet fitting to flange" to be flexibly adjusted to the installation situation.

- Remove the retaining clip (1) upward from the groove and turn the holder into the desired position.
- Press the holder together somewhat in the desired position and engage the retaining clip in the groove again
- Mount the holder in the vertical position. Recommended tightening torque for M8 screws: 10 Nm.
- Ensure sufficient strength of the screw and nut material.
- Connect the hoses to the inlet, outlet and oil return fittings (make sure a sufficient length of hose is pushed on) and secure with hose clamps (see Chap.4.2 and 4.3).
- Connect the oil return hose (and non-return valve if necessary) to the oil sump.
- To ensure proper functioning, the ProVent should be protected against dirt (mount splash guards if necessary).

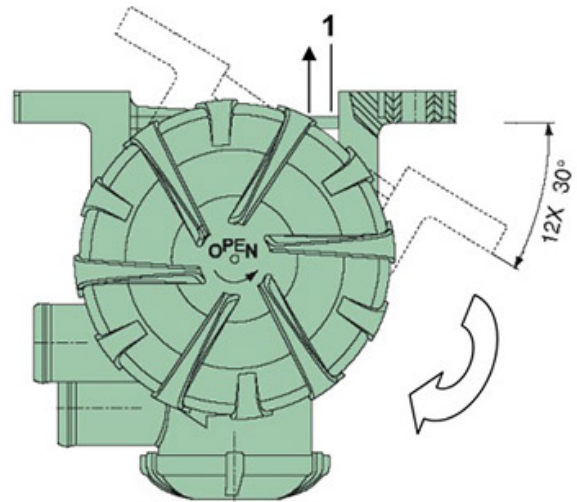

Fig. 5 Positions of outlet for ProVent 200

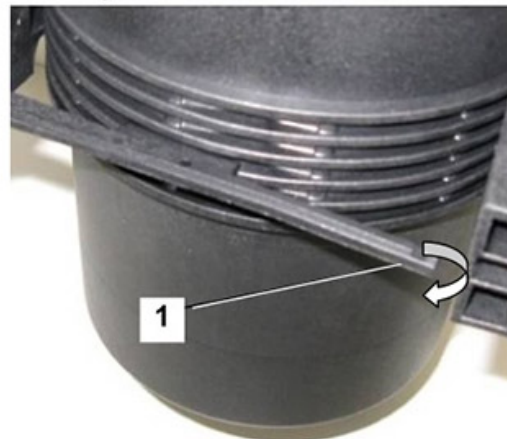

Fig. 6 Holder for ProVent 200